

# ROHS

## SPECIFICATIONS

Rated Current:1.5AMP  
 Contact Resistance:20mΩ Max  
 Withstand Voltage:400V AC/DC  
 Insulation Resistance:800MΩ Min  
 Operation Temperature:-40°c to +105°c

Contact Material:Brass  
 Contact Plating:Au Over Ni  
 Insulator Material:Polyester(UL94V-0)

Standard: PA6T  
 Max.Processing Temp: 230°C for 30-60 seconds  
 (260°C for 10 seconds)

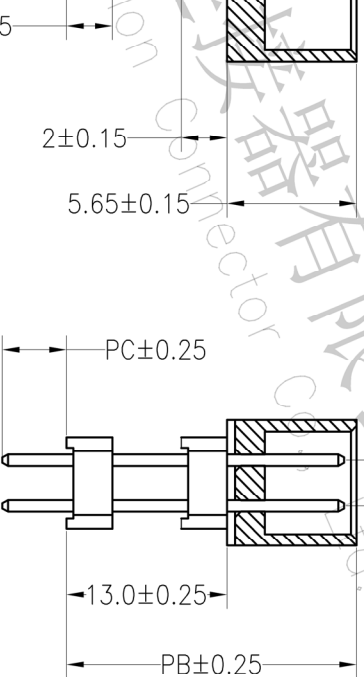
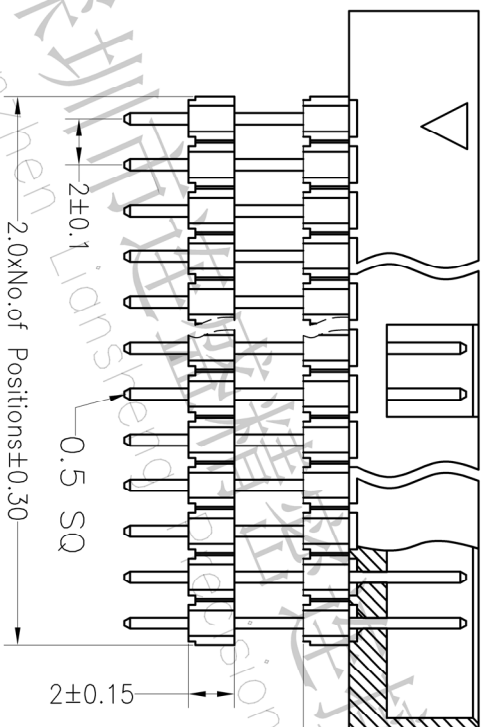
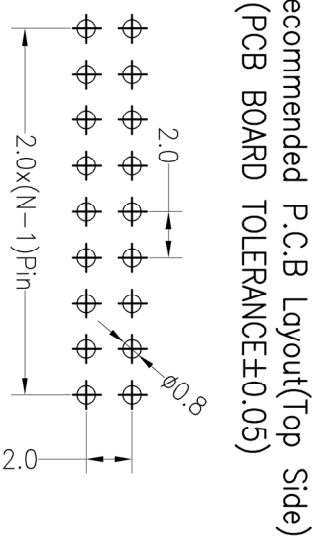
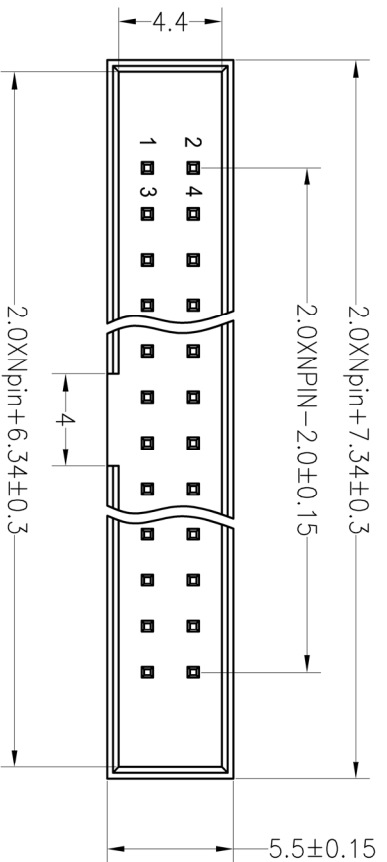

## Ordering Information

产品型号 J=筒子	间距 1=1.27 2=2.0 3=2.54 4=3.96 5=5.08 7=5.08 A=1.27x2.54	总引针数 016=16P	产品形态 1=DIP 2=PA 3=SMT 4=SH 5=线端脚	绝缘厚度 00=常规 01=1u" 02=2u" 03=3u" SN=镀锡	塑胶材料 1=PBT 2=LCP 3=PPS 4=PA46 5=PA6T 9=PA9T	塑胶颜色 1=黑色 2=灰色 3=白色 4=蓝色 5=红色 7=灰白色	包装方式 1=散装 2=卷装 3=盘装 4=袋装 5=盘装	序列号 0001-9999
J	X	XXX	X	XX	X	X	X	XXXX

## Dimension antitheses list

ITEM	PB	PC	L	H	W
001	18.6	2.8	21.0		
002					



深圳市连盛精密连接器有限公司  
 Shenzhen Liansheng Precision Connector Co., Ltd.

OPERATION		DRAW		SCALE		FIT		PART NO.	
X.X	±0.30	X.X	±0.30	UNIT	mm	A4	1/1	TITLE:	
X.XX	±0.20	CHECK		SIZE	A4	SHEET		2.0Box 2*NP 3H=5.65+2X2.0 180°	
X.XXX	±0.10	APPROVE		PROJ.	1/1	SHEET		PB18.6 PC2.8	
Angle	±3°	CHANGE		DIM		TOL			
A0	2012.03.28	NEW DRAWING		MODIFICATION DESCRIPTION		DATE			
REV	1	2		3		4		5	

