

RoHS

Recommended P.C.B Layout(Top Side)
(PCB BOARD TOLERANCE±0.05)

SPECIFICATIONS

Rated Current:1.0AMP
Contact Resistance:20mΩ Max
Withstand Voltage:500V AC/DC
Insulation Resistance:1000MΩ Min
Operation Temperature:-40°C to +105°C

Contact Material:Brass
Contact Plating:Au or Sn Over Ni
Insulator Material:Polyester(UL94V-0)
Standard: PA6T
Max.Processing Temp: 230°C for 30-60 seconds
(260°C for 10 seconds)

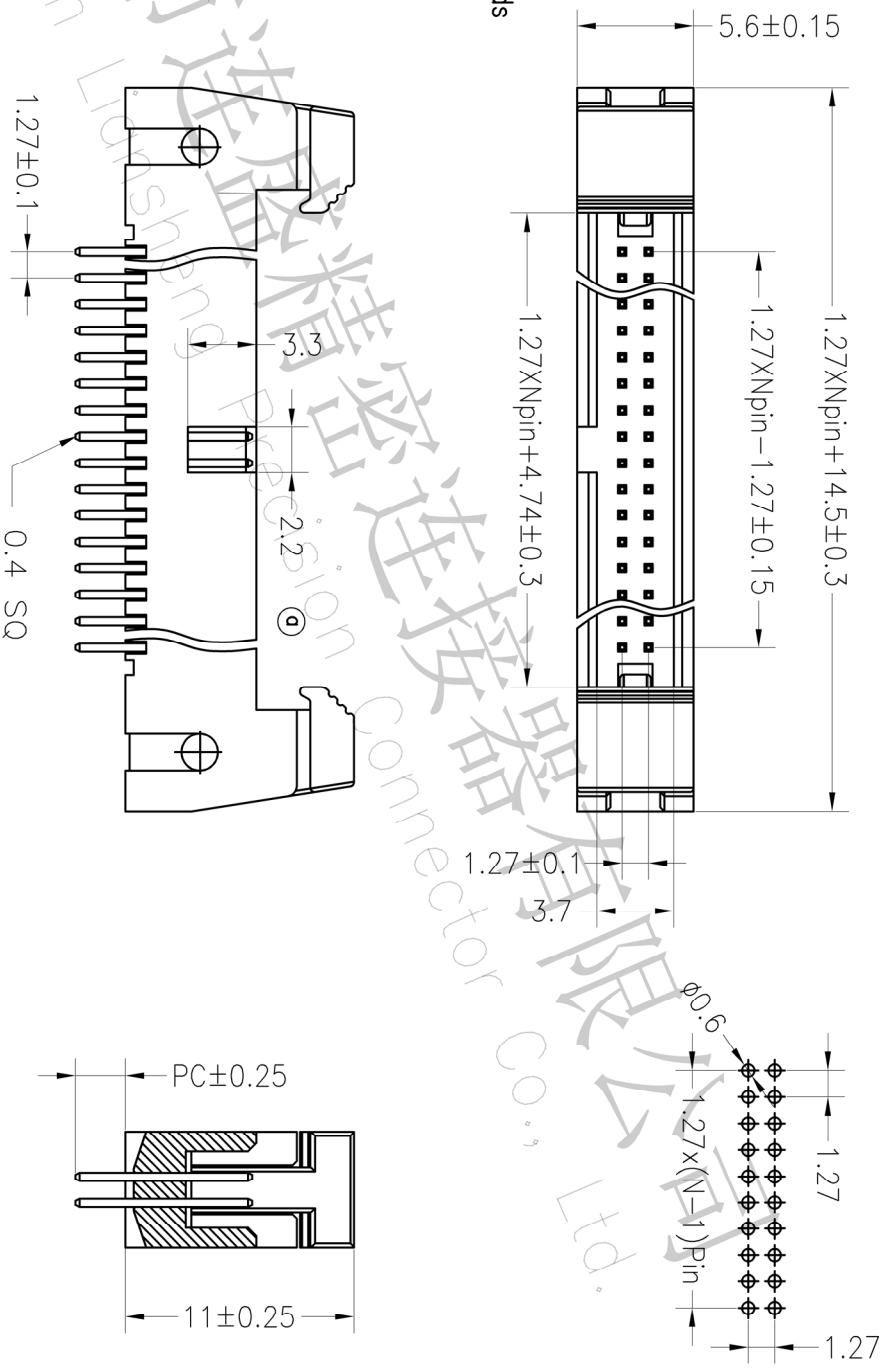

Ordering Information

N	X	XXX	X	XX	X	X	X	XXXX
产品类别 N=1角	间距 27	总Pin数 016=18P	产品形态 1=PIA 2=PIA 3=SMT 4=SH 5=板级脚	电镀厚度 00=有镀 01=无	绝缘材料 1=PI 2=PS 3=PPS 4=PA66 5=PA6T 9=PA9T	塑胶颜色 1=黑色 2=灰色 3=白色 4=蓝色 5=红色 6=米白色 7=米白色	特殊规格 1=标准 2=长耳 3=短耳 4=中耳	序列号 00015969

ITEM	PB	PC	PW	H	W
001		2.4			
002					

深圳市连盛精密连接器有限公司
Shenzhen Liansheng Precision Connector Co., Ltd.

OPERATION		DRAW		SCALE		FIT		PART NO.	
X.X	±0.30			UNIT	mm				
X.XX	±0.20	CHECK		SIZE	A4				
X.XXX	±0.10			SHEET	1/1				
Angle	±3°	APPROVE		PROJ.					
DIM	TOL								
CHANGE									
REV	DATE	MODIFICATION DESCRIPTION							
A0									
A1									
1									

TITLE: 1.27#角-Npin 180° L8.5