

# RoHS

## SPECIFICATIONS

1.MATERIAL:  
Housing: LCP UL 94V-0  
Color: Black  
Contact: Phosphor bronze  
Peg: Brass

2.FINISH:  
Contact:3u" Gold/Tin plating on contact area  
100u" min.Tin-Lead Plating on soldertails  
50u" min.Nickel underplating over all  
PEG: 100u"min.Tin-Lead plating on soldertails  
50u"min.Nickel underplating over all

Recommended P.C.B Layout(Top Side)  
(PCB BOARD TOLERANCE±0.05)

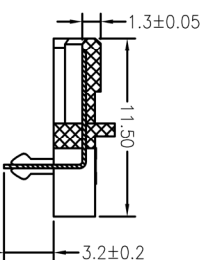
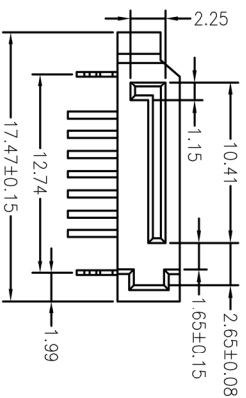
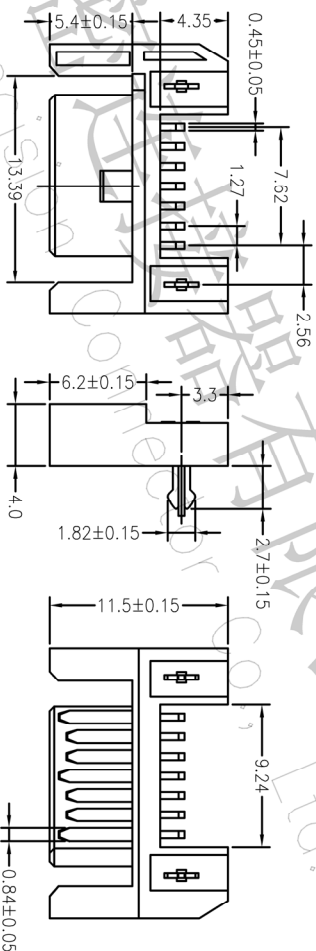
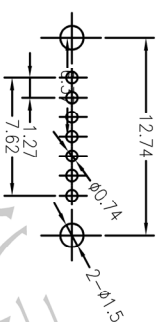

## Ordering Information

S G 07 T X X G01 000

S=SATA Header  
G=Male  
07=7P  
T=The harpoon  
X=X  
X=X  
G01=1UGold/Tin  
G03=3UGold/Tin  
G05=5UGold/Tin  
G010=10UGold/Tin  
G015=15UGold/Tin

S=Straight  
M=SMT  
B=BOX  
C=TUBE  
D=TAPE  
REEL

REV	DATE	MODIFICATION DESCRIPTION	CHANGE	OPERATION		DRAW	SCALE		FIT	PART NO.	TITLE:
				DIM	TOL		UNIT	mm			
A0	2012.03.28	NEW DRAWING		X.XX	±0.30	CHECK	A4	1/1			
1				X.XXX	±0.10	APPROVE	SIZE	1/1			
				Angle	±3°		SHEET				
							PROD.				

**深圳市连盛精密连接器有限公司**  
Shenzhen Liansheng Precision Connector Co., Ltd.

SATA7P 公头 正向 90°