

RoHS

SPECIFICATIONS

1. MATERIAL:

Housing: LCP UL 94V-0
 Color: Black
 Contact: Phosphor bronze
 Peg: Brass

2. FINISH:

Contact: 3u" Gold/Tin plating on contact area
 100u" min. Tin-Lead Plating on soldertails
 50u" min. Nickel underplating over all
 PEG: 100u" min. Tin-Lead plating on soldertails
 50u" min. Nickel underplating over all

Ordering Information

S G 07 X X X G01 000

S=SATA
 G=Male Header
 07=7P
 T=The harpoon
 G=Ground lug
 S=Strait
 M=SMT
 B=BOX
 C=TUBE
 D=TAPE
 REEL

G01=1UGold/Tin
 G03=3UGold/Tin
 G05=5UGold/Tin
 G010=10UGold/Tin
 G015=15UGold/Tin

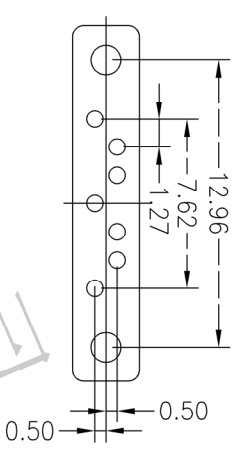
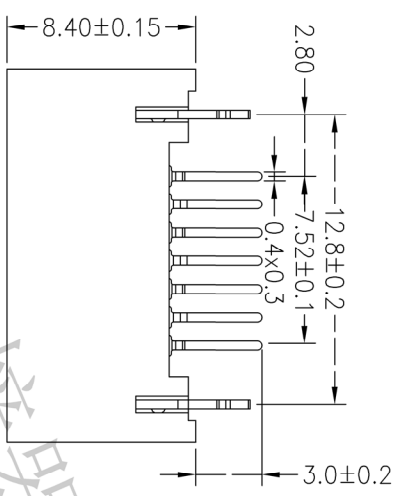
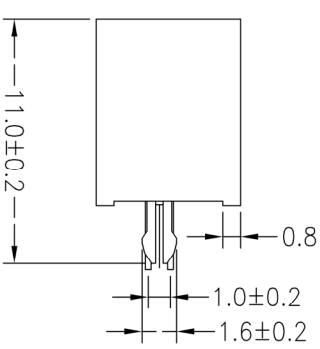
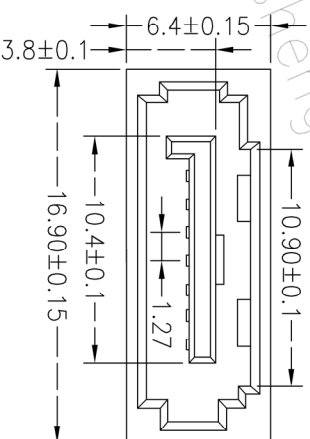

Recommended P.C.B Layout(Top Side)
 (PCB BOARD TOLERANCE±0.05)

OPERATION		DRAW		SCALE		FIT		PART NO.	
X.X	±0.30	X.X	±0.30	UNIT	mm	SIZE	A4	SHEET	1/1
X.XX	±0.20	CHECK		APPROVE		PROJ.		TITLE:	SATA7P公头 全开不开闩A型插板PC3.0
A0	2014.04.27	NEW DRAWING							
REV	DATE	MODIFICATION DESCRIPTION	CHANGE	DIM	TOL				
1									

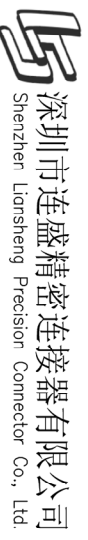

深圳市连盛精密连接器有限公司
 Shenzhen Liansheng Precision Connector Co., Ltd.