

# RoHS

## SPECIFICATIONS

### 1. MATERIAL:

Housig: LCP UL 94V-0  
 Color: Black  
 Contact: Phosphor bronze  
 Peg: Brass

### 2. FINISH:

Contact: 3u" Gold/Tin plating on contact area  
 100u" min. Tin-Lead Plating on soldertails  
 50u" min. Nickel underplating over all  
 PEG: 100u" min. Tin-Lead plating on soldertails  
 50u" min. Nickel underplating over all

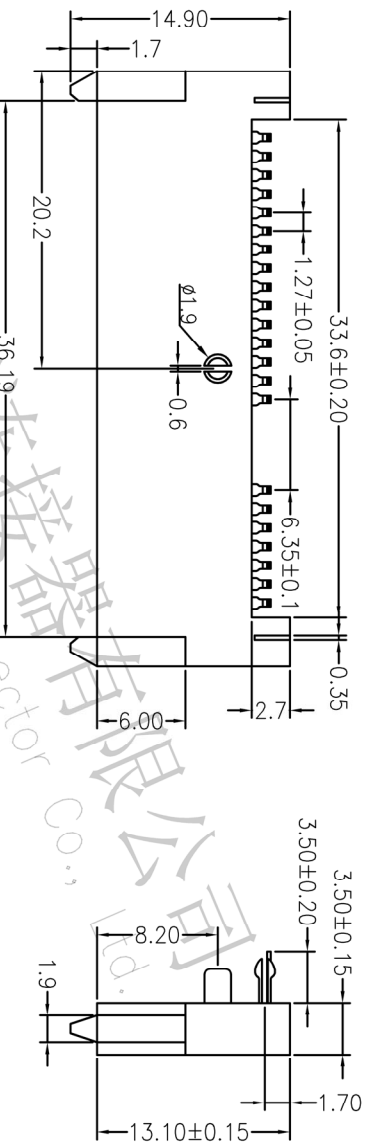
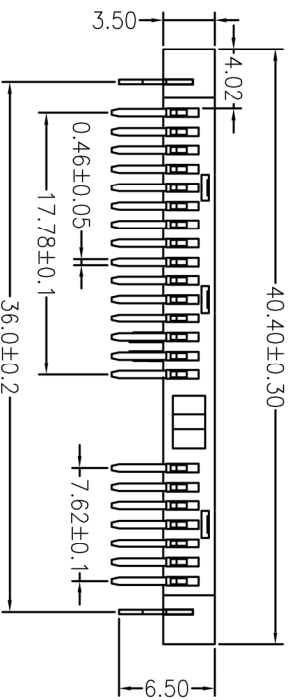

## Ordering Information

S M 22 350 X X G01 000

S=SMTA Header M=Female 22=7+1SP H=3.5

S=Straight B=80X C=TUBE  
 M=SMT R=Right D=TAP= REEL  
 Angle G01=1UGold/Tin  
 G03=3UGold/Tin  
 G05=5UGold/Tin  
 G010=10UGold/Tin  
 G015=15UGold/Tin

## RECOMMEND PCB LAYOUT

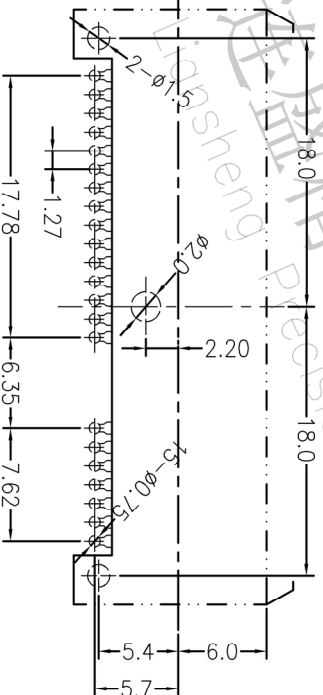

深圳市连盛精密连接器有限公司  
 Shenzhen Liansheng Precision Connector Co., Ltd.

		OPERATION		DRAW		SCALE		PART NO.	
		X.X	±0.30	FIT		UNIT		mm	
		X.XX	±0.20	CHECK		SIZE		A4	
		X.XXX	±0.10	APPROVE		SHEET		1/1	
		Angle	±3°	PROJ.		TITLE:			
		DIM	TOL						
A0	2014.04.27	NEW DRAWING							
REV	DATE	MODIFICATION DESCRIPTION	CHANGE						
1									

SATA7+15P 带中柱 板下 90度